

20 GHz Signal Source Core Module

The SC5511A is a compact, high performance VCO based synthesized signal source with frequency ranging from 100 MHz to 20 GHz. Despite its small modular form factor that fits into the palm of the hand, it packs the instrument grade performance of large box instruments. Boasting low phase noise of -115 dBc/Hz @ 10kHz offset from a 10 GHz carrier, tuning the entire band at 1 Hz resolution, and having amplitude step resolution of 0.01 dB over the range of -30 dBm to 13 dBm sets the SC5511A apart from other small modular synthesizers. Furthermore, using a unique multiple phase-locked loop architecture the phase spurs are typically kept below -70 dBc across the tuning range, even at 1 Hz step resolution. Furthermore, using a high fundamental frequency VCO (20 GHz) and eliminating multipliers, sub-harmonics due to dividers are typically less than -70dBc and far out spurious signals are also kept below -70 dBc.

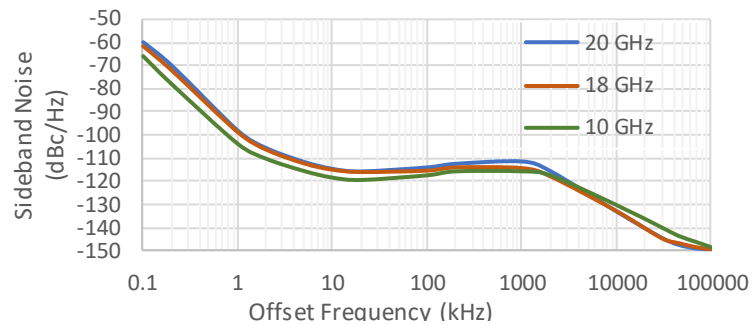

The SC5511A has an additional independent RF2 channel whose frequency range covers 100 MHz to 3 GHz with tuning resolution of 25 MHz. This makes the module ideal for both single-stage RF conversion systems, and dual-stage image suppression up/down converter systems. It makes a great general purpose laboratory signal source where demanding size, low phase noise, and signal purity are needed. It is also an ideal choice as an integrated clock source for fast DAC and ADC applications, especially those that require variable sampling rates.

Product Features

- Low residual phase noise typically -118 dBc/Hz at 10 kHz offset from 10 GHz carrier
- 100 MHz to 20 GHz output range
- 1 Hz tuning resolution (exact frequency)
- < -30 dBm to +10 dBm leveled output
- Spurious signals < -70 dBc typical
- Dual independent channels

Simplified Functional Diagram

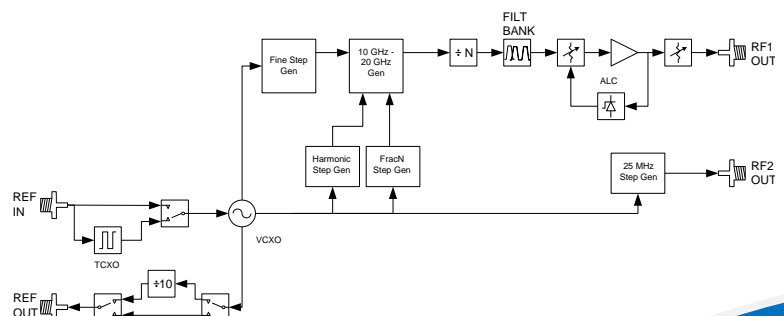

- RF instrumentation
- Wireless communications
- Signal intelligence
- Data converters

TECHNICAL SPECIFICATIONS (AT 25°C AMBIENT, SINE WAVEFORM)

RF1 SPECTRAL SPECIFICATIONS

RF output frequency range 100 MHz to 20 GHz
Internal reference
Stability ¹ ±200 ppb
Aging < 1 ppm after 1 year
Phase locking range ±5 ppm
Tuning
Resolution 1 Hz
Speed (settled to 1 ppm) ² < 500 us
Sideband phase noise ³ (dBc/Hz)

Offset	RF Frequency							
	1 GHz		5 GHz		10 GHz		20 GHz	
	typ	max	typ	max	typ	max	typ	max
100 Hz	-80	-74	-70	-65	-65	-60	-60	-55
1 kHz	-122	-116	-108	-104	-103	-98	-97	-92
10 kHz	-137	-128	-122	-115	-118	-110	-113	-108
100 kHz	-137	-129	-122	-115	-118	-110	-113	-108
1 MHz	-135	-129	-120	-115	-115	-110	-110	-105
10 MHz	-150	-145	-136	-134	-130	-128	-131	-130
Floor	-152	-145	-150	-144	-149	-145	-149	-145

Spurious Signals

< 10 MHz offset
Typical -65 dBc
max -55 dBc
> 10 MHz offset
typical -75 dBc
max -70 dBc

RF1 AMPLITUDE SPECIFICATIONS

Output range ^{4,5} -30 dBm to +13 dBm
Max output >+15 dBm typical
Amplitude resolution 0.01 dB
2nd order harmonics (0 dBm) < -20 dBc
Sub-harmonics <70 dBc typical
Output level accuracy ⁵ < ±1.0 dB typical

RF2 SPECIFICATIONS

RF range 100 MHz to 3 GHz
Frequency step resolution 25 MHz
Power output 5 dBm typical
2nd order harmonics (0 dBm) <-15 dBc
Phase Noise @ 1 GHz
1 kHz -110 dBc/Hz
10 kHz -118 dBc/Hz
100 kHz -118 dBc/Hz
1 MHz -142 dBc/Hz
10 MHz -160 dBc/Hz

TERMINAL SPECIFICATIONS

RF output terminals
Impedance 50 Ω
Connector type SMA female
Coupling AC
Reference input terminal
Impedance 50 Ω
Connector type SMA female
Coupling AC
Frequency 10 MHz
Amplitude range 0 dBm to +13 dBm
Lock range ±5 ppm
Reference output terminal
Impedance 50 Ω
Connector type SMA female
Coupling AC
Frequency 10/100 MHz
Amplitude +3 dBm typ

ENVIRONMENTAL

Operating temperature⁶ -10 °C to +55 °C
Operating relative humidity 10% to 90%, non-condensing
Operating shock 30g, half-sine pulse, 11 ms duration
Operating vibration 5 Hz to 500 Hz, 0.31 g_{rms}
Altitude 2000 m max (maintaining 25 °C ambient temperature)

General Specifications

Power consumption +12 V @ 1.6 A
Weight 1 lb
Dimensions (W x H x D, max envelope) .. 0.75" x 3.75" x 5.75"
Warranty 2 years parts and labor on defects in materials or workmanship

ORDER INFORMATION

7100045-01 SC5511A, 20 GHz Signal Source
USB and SPI Interfaces
7100045-02 SC5511A, 20 GHz Signal Source
USB and RS-232 Interfaces

Specifications are subject to change without notice. For the most recent product specifications, please visit www.signalcore.com.

- Internal reference is a TCXO. For better accuracies and stability SignalCore recommends phase-locking to a precision external source.
- For step change of less than 100 MHz and only when automatic level adjustment is turned off.
- Specified for channel RF 1 at power levels of greater than 0 dBm.
- Output leveled range is typically -30 dBm to +13 dBm for frequencies < 18 GHz. The leveled range is typically -30 dBm to +10 dBm for frequencies >18 GHz.
- Specified when amplitude control has the ALC in close loop operation. Output levels < -22 dBm, may degrade to ±2.0 dB typical. User must provide cooling to maintain internal device temperatures of 0 °C to 75 °C.