

BALUN BASICS PRIMER

上海馥莱电子有限公司
021-5291 8556
sales@fulai-elec.com
www.fulai-elec.com

A Tutorial on Baluns,
Balun Transformers, Magic-Ts,
and 180° Hybrids

By: Doug Jorgesen and Christopher Marki



INTRODUCTION

The balun has a long and illustrious history, first documented in the literature as a device to feed the television transmitting antenna for the Empire State Building¹ in 1939. Since then designs have evolved dramatically, and applications have evolved beyond driving differential antennas to include balanced mixers, amplifiers, and signaling lines of all types. Baluns have long been ubiquitous in low frequency audio, video, and antenna driving applications. The need for high speed, low noise data transfer has driven the advancement of the balun to higher frequencies and superior performance.

Despite these advancements, information about baluns remains scattered and confusing; this application note seeks to resolve this problem by clarifying the basic characteristics of baluns. First we will define what a balun is, what it does, and how it is different from other components. Next we will define generic balun specs, which we then use to discuss the different types of baluns and their properties. Finally we will discuss the applications of baluns and how to determine what kind of balun is required for several different purposes.

I. WHAT IS A BALUN?

A balun is any three port device with a matched input and differential outputs. It is most succinctly described by the required (ideal) S-parameters:

$$S_{12} = -S_{13} = S_{21} = -S_{31}$$
$$S_{11} = -\infty$$

Note what is implied by this:

- A balun is a three port power splitter, similar to a Wilkinson or resistive power divider.
- The two outputs will be equal and opposite.
 - In frequency domain this means the outputs have a 180° phase shift.
 - In time domain this means the voltage of one balanced output is the negative of the other balanced output.
- The unbalanced input is matched to the input transmission line impedance (usually 50 Ω).
- Unlike an isolator or circulator, a balun is a reciprocal device that can be used bidirectionally.

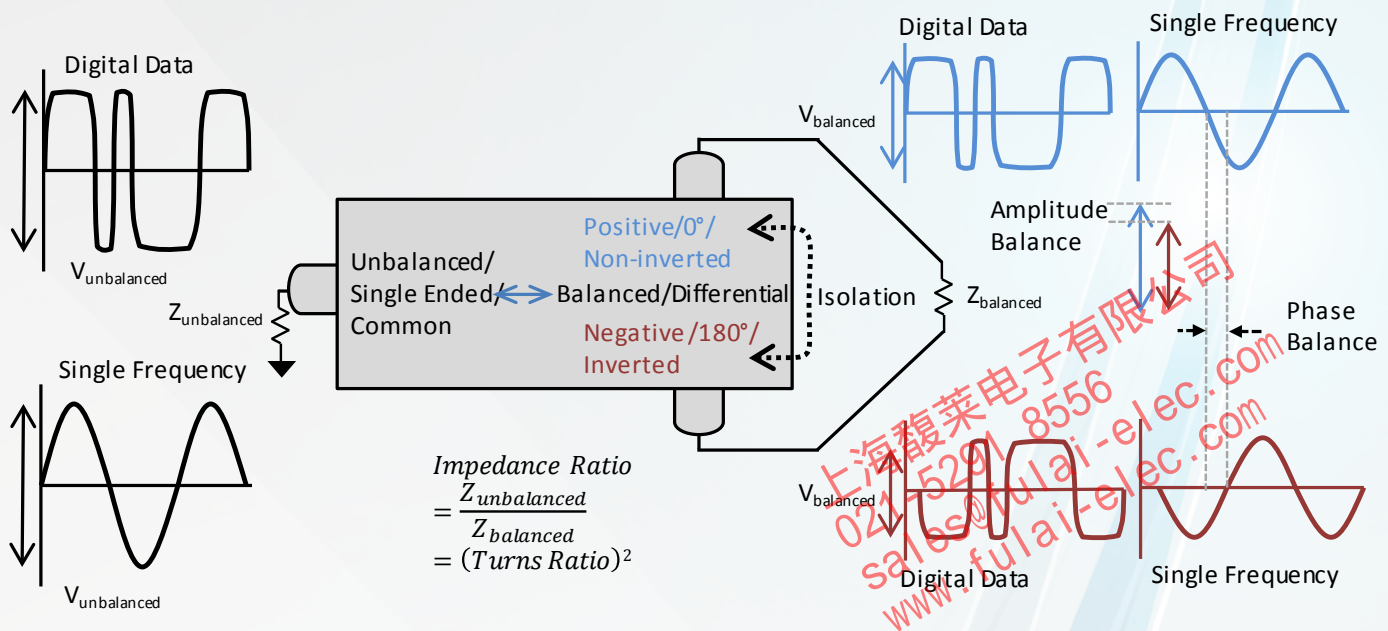

Fig. 1: Baluns convert between unbalanced and balanced signals

Also note what is not implied by this:

- The two outputs are not necessarily matched.
- The outputs of the balun may or may not be the same impedance as the input.
- There is no constraint on S_{23} , so the outputs may or may not have isolation.
- Therefore there may be a different return loss on the outputs for differential and common mode signals.

The term balun is a portmanteau of balanced and unbalanced, indicating that a balun will transition between a balanced (also called 'differential') transmission line (where opposite currents both travel in transmission lines) and an unbalanced (also called 'single ended') transmission line (where the return current travels in the ground). However, this description obscures the simplicity of the balun. A balun has equal power outputs just like a Wilkinson power divider, resistive power divider, or quadrature hybrid coupler. However, it has a 180° phase difference between outputs, while the power dividers have 0° phase difference and quad hybrids have 90° phase difference.

At low frequencies, the terms balun and transformer are often used interchangeably because low frequency baluns are almost always implemented using flux coupled transformers. For this reason it is often said that a balun is a type of transformer, but it is more accurate to say that a transformer can sometimes be used to implement a balun. Many other structures can also be used to implement balun functionality, as we will discuss in section IV. Before discussing the virtues of different types of balun structures, we need to define what performance specs are important for baluns.

II. BALUN PERFORMANCE SPECS

Frequency coverage: As with all RF/microwave circuits, each performance metric is only valid across some specified bandwidth. Increasing the bandwidth from octave, to decade, to multi-decade without sacrificing performance is a major challenge. In general Marki baluns can be divided into two types. Those with magnetic coupling perform below 10 MHz, while those with only capacitive coupling have low end performance limited to about 1 GHz, but can operate up to millimeter wave frequencies.

Phase Balance: The most important performance criterion is how close the balanced outputs are to having equal power and 180° phase, called balance. Phase balance is the measure of how closely the inverted output is to 180° out of phase with the non-inverted output, usually given in degrees. It is the most critical parameter for many balun applications. In addition to the quality of the balun structure, how closely matched the lengths of the output lines are determines the balance. Typical phase balance for standard microwave baluns is $\pm 15^\circ$ max and $\pm 10^\circ$ typical, while high performance Marki baluns approach $\pm 5^\circ$ max and $\pm 2^\circ$ typical.

Amplitude Balance: Related to phase balance, amplitude balance is also determined by construction and line matching. Although it is called amplitude balance, it is usually specified in dB and actually gives the match between output power magnitude. Low performance baluns have amplitude balance of ± 1.5 dB max and ± 1 dB typical, while Marki products approach ± 0.5 dB max and ± 0.2 dB typical.

Common Mode Rejection Ratio: If two identical signals with identical phase are injected into the balanced ports of the balun (called 'common mode' or 'even mode' signals), they will be either reflected or absorbed. The amount of attenuation this signal will experience from the balanced to unbalanced port is called common mode rejection ratio (CMRR) and is expressed in dB. It is determined by the vectorial addition of the two signals, and therefore is dependent on the amplitude and phase balance of the balun. The relationship between amplitude balance, phase balance, and CMRR is shown in Fig. 2. As a rule of thumb, a 0.1 dB improvement in amplitude balance will improve the CMRR by the same amount as a 1° improvement in phase balance. A low performance balun will have 15-20 dB of CMRR, while Marki baluns can achieve 25-55 dB of CMRR.

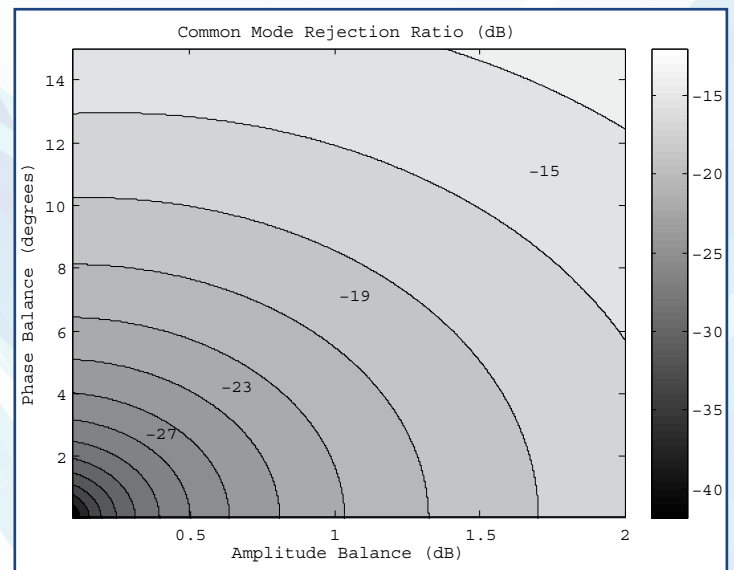

Fig. 2 Common Mode Rejection Ratio (in dB) as a function of amplitude and phase balance

Impedance Ratio/Turns Ratio: While the unbalanced impedance of a balun is matched to the input transmission line, the balanced impedance can be any value. The ratio of the unbalanced impedance to the balanced impedance is the impedance ratio, and is usually stated as 1:n (i.e. 1:1, 1:2, 1:4). Note that the differential impedance is between the balanced signal lines. This is twice the impedance between the signals and ground. A related value is the turns ratio, which for a flux coupled balun transformer is the ratio of primary windings to secondary windings. The impedance ratio is the square of the turns ratio (i.e. a 1:2 turn ratio gives a 1:4 impedance ratio). A higher output impedance will provide increased voltage at a reduced current, which is desirable for matching into high impedance semiconductor devices. High impedance ratio baluns are easy to design using flux coupled transformers, but much more difficult for transmission line transformers and other high frequency constructions.

Insertion and Return Loss: A lower insertion loss and higher return loss will mean more power available for downstream functions, an improved dynamic range, and less distortion of signals in previous stages of the system. In a balun without isolation, as in a reactive splitter, the return loss of balanced ports will be different for common mode and differential mode signals. In an ideal balun without isolation, the common mode signal would be perfectly reflected, with a return loss of 0 dB, while the differential signal would pass through completely with a return loss of $-\infty$. To properly characterize this effect one can use mixed-mode S-Parameters instead of standard S parameters to determine how the device will operate with differential inputs².

Balanced Port Isolation: Usually referred to simply as isolation, this has the same meaning as in other power dividers and couplers, namely the insertion loss from one balanced port to the other in dB. Most baluns do not offer high isolation because the even mode is reflected instead of being properly terminated with a resistive load. The exception is 180° hybrid circuits, where the even mode is output to a port that can be resistively terminated.

DC/Ground Isolation: Different from the balanced port isolation, DC isolation is whether the unbalanced port has a DC connection to one of the balanced ports. Ground isolation is whether there is a connection between the unbalanced ground and the balanced signals or grounds.

Group Delay Flatness: For data transmission applications, a flat group delay will ensure a minimal amount of distortion. Group delay flatness is the difference from the average delay across frequencies. This parameter can most easily be evaluated by either measuring directly on a VNA or examining the output eye diagrams from an input amplitude shift keyed signal. Unwanted group delay ripple is related to poor broadband matching. Baluns with superior return loss will have superior group delay flatness.

III. TYPES OF BALUNS

The most common type of balun by volume is the flux coupled balun transformer. This is a balun created by winding two separate wires around a magnetic core (the same as any transformer), and grounding one side of the primary winding. This creates an unbalanced condition on the primary side, and a balanced condition on the secondary side. In addition, the secondary side can have an arbitrary ratio of turns to the primary side, creating an arbitrary impedance ratio (the theory of a transformer is explained in many introductory electrical engineering texts).

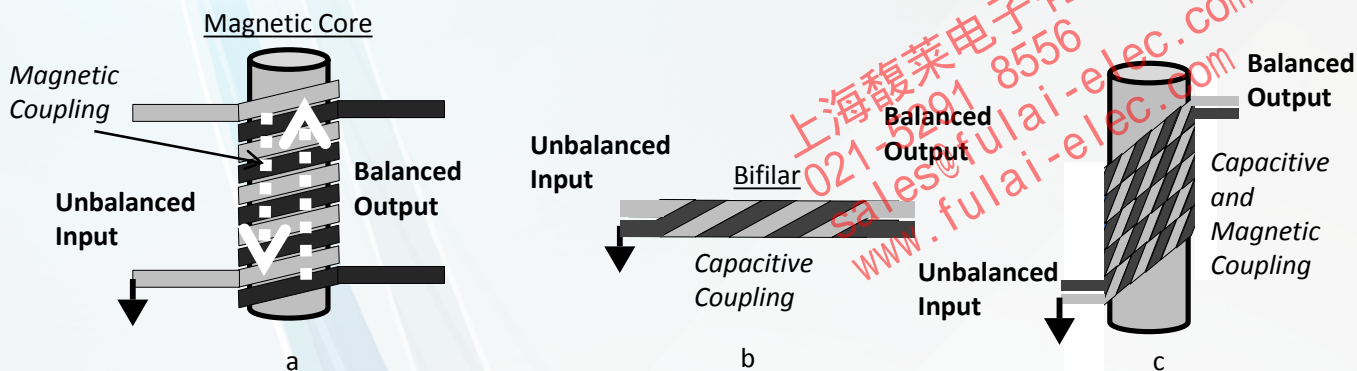

Fig. 3 Construction of a) a flux coupled balun transformer using two wires wrapped around a common magnetic core, b) a transmission line balun consisting of a bifilar coil of two wires wound around each other, with one end connected to ground, and c) a transmission line balun using magnetic core for additional low frequency coupling

The flux coupled balun transformer will induce an AC voltage in the secondary of n times the voltage in the primary, while the current will be n times smaller than in the primary, giving an output impedance of n^2 as stated above, where n is the ratio of turns in the secondary to turns in the primary. The circuit symbols typically used for a balun transformer are shown in Fig. 4. Circuit diagrams typically use a dot convention to indicate which side corresponds to the input polarity. Wire wound flux coupled transformers will often have a center tap in the secondary winding. In the middle of the secondary winding a virtual ground exists, and connecting this point to the ground of the secondary system can improve the balance of the output.

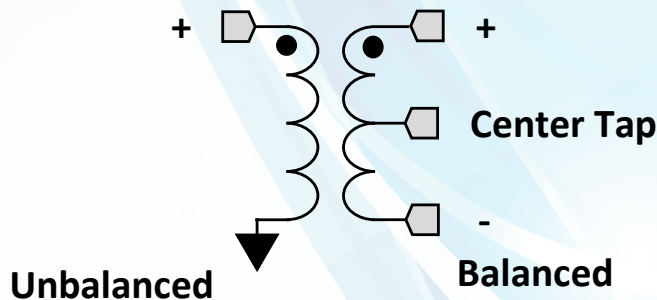

Fig. 4 Circuit symbol for a flux coupled balun transformer, showing the dot convention and center tap

Ideally, a flux coupled transformer could be used whenever balun functionality is required. It is well understood, relatively simple to build, provides an arbitrary impedance ratio than can be easily tuned, and provides both DC and ground isolation. Unfortunately they are generally limited to frequencies below 1 GHz. At higher frequencies the dipoles in the magnetic material cannot switch fast enough, and the balun loses coupling. The parasitic capacitance between wires causes high frequency signals to travel directly to ground without coupling through the magnetic material. Magnetic materials also always possess a large loss tangent, leading to high signal losses at microwave frequencies.

Because of these difficulties, the capacitively coupled transmission line balun was developed. This is a set of coupled lines with one end grounded, such that the coupling will induce equal and opposite signals in both lines. Converting the ground to a transmission line allows the signal to be used differentially. This can be done in many ways, most often with a bifilar transmission line wrapped around a magnetic core to take advantage of the low frequency magnetic coupling as well as the high frequency capacitive coupling (Fig.3c). This basic structure can be connected in many different ways; the more common forms include the 1:4 impedance ratio Ruthroff balun and 1:4 Guanella balun³.

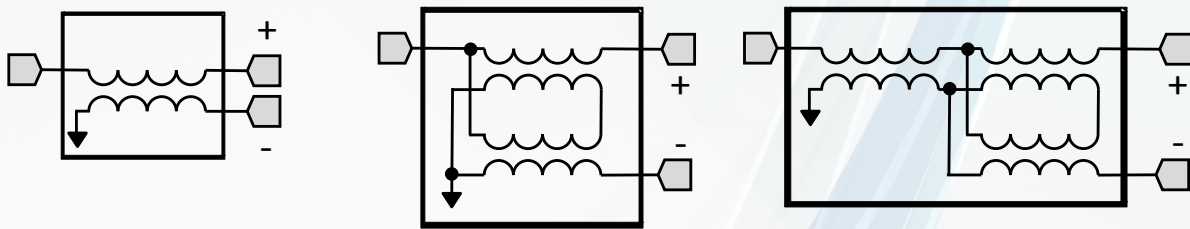

Fig. 5 Circuit diagram of a 1:1 transmission line balun (left), 1:4 Guanella balun (center), and one type of 1:4 Ruthroff balun (right)

This functionality can also be performed with a microstrip transmission line where the ground plane is simply tapered into a bottom transmission line. This structure, called a tapered balun (also called microstrip-to-balanced stripline balun, Fig. 6), has the advantage of high frequency operation but the disadvantages of no low frequency capability and a difficult-to-implement geometry. The tapered balun, in turn, is very similar to other type of coupled line baluns such as the Marchand balun (Fig. 7), coplanar waveguide balun, coaxial balun, planar transformer (spiral) balun, and many other types of coupled line circuits that can be used as baluns, and will not be reviewed here.

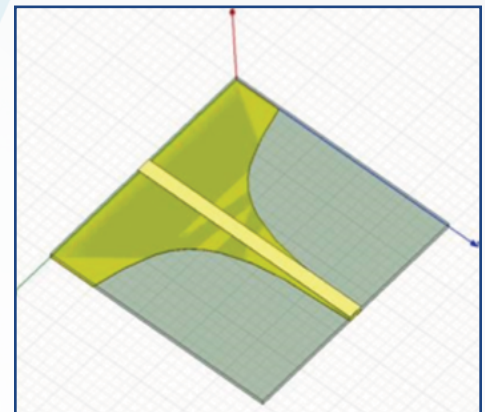

Fig. 6 Tapered microstrip balun

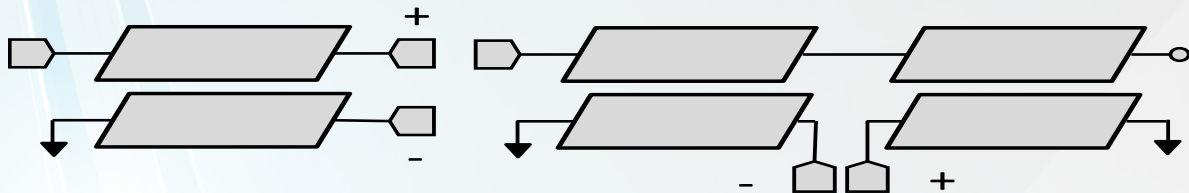

Fig. 7 Circuit diagram of a capacitively coupled transmission line balun (left) and basic Marchand Balun (right)

These types of baluns are all based on quarter wavelength sections of transmission lines, which means that they need to be longer (and higher loss) to operate at lower frequencies. This limits the practical low end of the frequency band to around 500 MHz to 1 GHz. On low dielectric substrates the parts will be larger (and usually lower loss), while on higher dielectric substrates they will be smaller (and higher loss). For example a quarter wavelength section at 1 GHz on a 2.2 dielectric substrate will be 2.15" long, therefore the minimum length of a Marchand balun would be 4.3" long. Conversely at 10 GHz, the same balun would be 0.430" long and easily printed using standard fabrication methods.

All the previously mentioned baluns are of one type, where coupling of some sort is used to float the ground of an unbalanced transmission line, creating a balanced transmission line. Another type of balun is one where an in phase power division is performed first, and then a 180° phase shift is applied to one of the outputs, creating a balanced output. This structure is not to be confused with the 180° power divider, which is discussed below. This phase shift can be narrow band, such as a half wave transmission line, or a broadband phase shift such as an inverter (Fig. 8). This technique is commonly used to create higher frequency baluns for test and measurement. A half-wave balun uses a ladder of quarter wave transformers combined with half wave transmission sections to expand the bandwidth of a simple single frequency balun. Another method is to use a coupler 90° phase shift on one arm and a coupler with a -90° phase shift on the other arm.

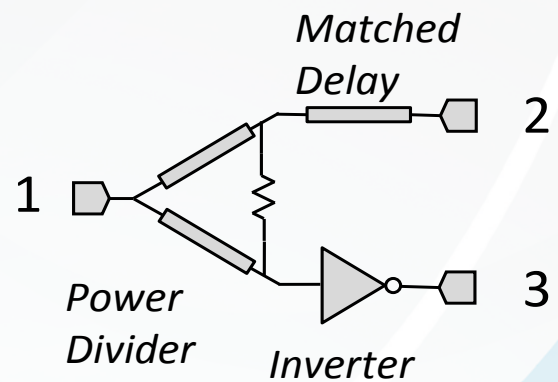

Fig. 8 Phase shift balun

These baluns can achieve multi-octave bandwidth if they use interdigital Lange couplers.

The final type of balun is the 180° power divider, which is a balun with isolation between the outputs. These are implemented using 180° hybrid junctions (Fig. 9). These are similar in function to 90° hybrid couplers, but they have a phase shift of 180° between the non-isolated ports. They have the property that from two inputs, the common or even mode will output from one port (the Σ or sum port), while the differential or odd mode will appear at a different port (the Δ or difference port). A 180° hybrid coupler can be made into a 180° power divider by terminating the sum port with a 50 Ω load. These types of circuits suffer from the same quarter wavelength length requirements as capacitively coupled baluns. Common examples of 180° hybrid couplers include the rat race coupler, the asymmetric tapered coupled line coupler, and the magic-T (Fig. 10). Interestingly, a Wilkinson power divider is actually a type of 180° hybrid where the sum port is terminated with a lumped resistor, called the isolation resistor.



Port 1	Port 2	Port 3	Port 4
Input	Isolated	Input/2	Input/2
Isolated	Input	Input/2	-Input/2

Fig. 9 Schematic and I/O table for a 4-port hybrid junction

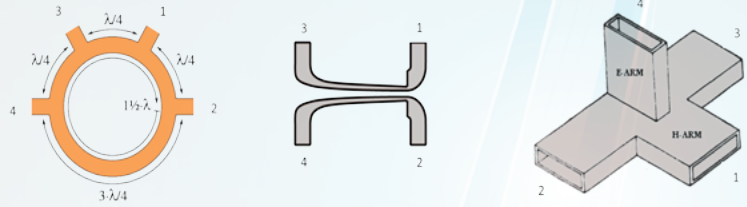

Fig. 10 Rat Race Coupler (left), asymmetric tandem coupler (center), and Waveguide Magic-T (right)

Balun Type	Max BW Ratio	Practical Frequency Range	Balance	Isolation	Common Impedance Ratios	Applications
Flux Coupled Balun Transformer	10 ⁶ :1	20Hz – 1 GHz	Fair - Excellent	With center tap	Arbitrary	Balanced Transmission Lines, Differential Antennas
Wire-wound Transmission Line Balun	10 ⁵ :1	500 kHz – 10 GHz	Fair - Excellent	No	1:1, 1:4	Interface to Differential ICs (ADC/DACs)
Capacitively Coupled Transmission Line Balun	10 ² :1	.5 – 65 GHz	Fair - Excellent	No	1:2	Balanced Mixers, Push-Pull Amplifiers, Signal Combining
Power Divider - Inverter Balun	10 ⁶ :1	200 KHz – 65 GHz	Fair	Depends on Power Divider	1:2	Test Instruments
Half Wave Balun	<2:1	.5-60 GHz	Good	No	1:2	Mixers
Rat Race Coupler	<2:1	.5-50 GHz	Fair	Yes	1:2	Mixers, Duplexers
Asymmetric Tandem Coupler	10:1	.5-40 GHz	Fair	Yes	1:2	Mixers, Duplexers, Amplifiers, Antenna Arrays
Waveguide Magic T	<2:1	1-146 GHz	Fair	Yes	1:2	Mixers, Duplexers, Amplifiers

IV. APPLICATIONS OF BALUNS

The most common application of baluns is to interface an unbalanced signal to a balanced transmission line for long distance communications. Differential signaling on balanced transmission lines is more immune to noise and crosstalk, can use lower voltages, and is lower cost than single-ended signaling on coaxial cables. Hence, it is used for most common intermediate and long distance transmission lines such as RS-422, RS-485, Ethernet over twisted pair, PCI Express, DisplayPort, HDMI, and USB. Therefore, baluns are used to interface local video, audio, and digital signals to long distance transmission lines. In these applications the most important characteristic is common mode rejection ratio. The second most important application of baluns is for driving differential antennas. There is an abundance of literature from amateur ham radio operators on techniques to build and operate baluns for various antenna patterns to maximize the antenna gain⁴. As in differential signaling, the rejection of common mode current is the most important metric for an antenna feed balun, although performance also requires proper impedance ratios and matching to the antenna.

Another extremely high volume application is the use of baluns to create balanced devices such as push-pull amplifiers and balanced mixers (Fig. 11). Push-pull amplifiers work by splitting the signal into a positive and negative version with a balun, amplifying them, and then recombining the signals with another balun. One advantage of this scheme is that the saturated output power can be doubled. Alternatively the input power to each amplifier can be reduced by half for a given output power, significantly reducing the distortion products created by higher input powers. Another benefit is that this scheme will dramatically reduce, by the baluns' CMRR, the second order distortion outputs of the amplifier. The second order and all other even order distortion products will be identical in both amplifiers, while the fundamental will be out of phase. Therefore all even order products will be canceled in the output balun, while the odd order products pass through.

It is this even product cancellation that can be used to dramatically reduce spurious products in balanced mixers like the double balanced mixer shown in Fig. 11. In this structure not only are the even order distortion products of both the RF and LO canceled out, but also the fundamental of the LO will be canceled out traveling to the RF and IF ports. Marki Microwave has been using this technique to design the world's best mixers for many decades. Owing to our vast experience designing baluns for mixer applications, Marki Microwave can now offer discrete baluns to meet the most demanding requirements.

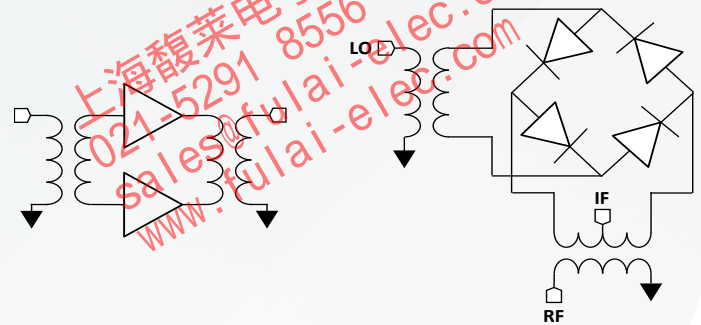

Fig. 11 Push-Pull Amplifier (left) and Double Balanced Mixer (right)

Marki offers high performance connectorized and surface mount baluns. Our connectorized baluns are typically used for interfacing high speed differential chips to unbalanced signals, either from test equipment or receivers, for testing purposes. These units allow single ended test equipment such as synthesizers, oscilloscopes, power meters, and network analyzers to interface with differential devices such as cables, differential amplifiers, receivers, and transmitters. This is very important for differential devices, since they will generally behave quite differently when excited with a differential signal vs. when they are excited with a single ended signal (which can be decomposed into both differential and common mode signals). In particular, a 2 port VNA can be used to measure differential devices with a matched set of baluns, but special care must be taken to de-embed the baluns if they do not have isolation⁵.

Our broadband, high performance surface mount baluns are most frequently used as the interface between high speed digital converters and heterodyne transmission systems. In this circumstance designers are replacing what was previously the final IF transmission stage for these heterodyne converters. In this application the most important spec for the balun is the phase balance. An improvement from 12 degrees of phase balance to 3 degrees of phase balance can improve the even order dynamic range of the ADC by more than 10 dB⁶.

Matching a wideband analog to digital converter (ADC) to a single ended source is a difficult challenge, especially when using super-Nyquist sampling (at frequencies above the fundamental Nyquist zone). A differential amplifier at the front end will add noise and degrade linearity, while a balun will provide voltage gain without adding noise (an ADC responds to voltage,

which will be $\sqrt{2}$ higher or more depending on the impedance ratio at the differential outputs of a balun). The input impedance of an ADC is typically much higher than 50 Ω , generally in the k Ω range. This means that a higher output impedance balun will generally match better to an ADC input than a 1:1 balun.

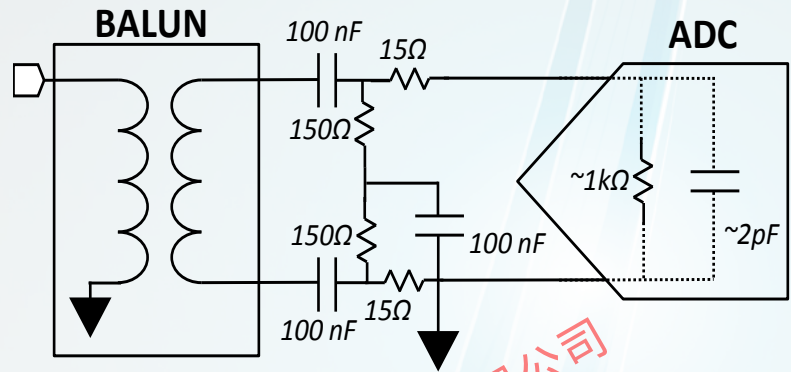

Fig. 12 ADC Matching Circuit using a Balun⁷

An example ADC matching circuit is shown in Fig. 12.

It involves AC coupling capacitors, parallel resistors, and inductance to match the capacitive, high impedance ADC load to the transmission line input. It also includes series resistors to limit any amount of charge injection coming from the ADC's internal sampling structure back into the analog system. Due to the band-limiting nature of the ADC, it is often necessary to use a balun that is much wider band in a pure 50 Ω system than the required system bandwidth.

SUMMARY

Because the term 'balun' encompasses a wide range of devices and applications, the information on them is scattered and confusing. In this application note we have clarified that baluns are differential power dividers. They can be built as transformers, capacitively and/or magnetically coupled transmission lines, hybrid couplers, or as a combination of a power divider and an inverter. Their most important characteristic is how well balanced they are in power, and how close to 180° out of phase their balanced ports are. Baluns can be used for many applications to transition between single ended and differential signals and to cancel common mode noise and signals. The future of baluns lies in further improving the balance, increasing the power handling, and reducing the size, complexity, and cost in these critical communications applications.

FOOTNOTES

- 1 N.E. Lindenblad, "Television transmitting antenna for Empire State Building," RCA Rev., vol. 3, pp. 387-408, April 1939.
- 2 Bockelman, D.E., Eisenstadt, W.R., "Combined differential and common-mode scattering parameters: theory and simulation", Microwave Theory and Techniques, vol. 43, no. 7, 1995, pp. 1530-1539.
- 3 Gustav Guanella (1909-1982) was a brilliant Swiss inventor and manager with over 200 patents. He developed the basic transmission line balun, and the one that bears his name, to match a high impedance power amplifier to a low impedance antenna. His sister married Albert Hoffman, inventor of LSD. Clyde Ruthroff was a scientist at Bell Labs from 1946-1977. In his paper, 'Some Broad-Band Transformers', he actually proposes 9 different transformers that became the basis of hundreds of variations. We show only one here.
- 4 Most important is Jerry Sevick, who was drafted by the Chicago Bears, but instead spent his career working on antennas at Bell Labs. He also coined the term 'unun' to describe an unbalanced
- to unbalanced impedance transformer. See Jerry Sevick, W2FMI, Understanding, Building, and Using Baluns and Ununs, CQ Communications, 2003.
- 5 For more information see "The Problem with Back to Back Baluns", Marki Microwave Tech Notes, <http://www.markimicrowave.com/blog/2013/11/the-problem-with-back-to-back-baluns/>
- 6 For more information see "Why buy a high quality balun/ transformer for an analog to digital converter (ADC)?", Marki Microwave Tech Notes, <http://www.markimicrowave.com/blog/2013/07/why-buy-a-high-quality-baluntransformer-for-an-analog-to-digital-converter-adc/>
- 7 See Rob Reeder, "Wideband A/D Converter Front-End Design Considerations: When to Use a Double Transformer Configuration", <http://www.analog.com/library/analogDialogue/archives/40-07/transformer.pdf>

上海馥莱电子有限公司
021-5291 8556
sales@fulai-elec.com
www.fulai-elec.com



© 2014 Marki Microwave, Inc. | 215 Vineyard Court | Morgan Hill, CA 95037

P 408.778.4200 | F 408.778.4300 | support@markimicrowave.com

www.markimicrowave.com